



SHR

SHEFFIELD HI-TECH REFRACTORIES
Germany GmbH

To: **KSCO**

Date: **28.06.2021**

Attn.: **GHOLAMREZA MARDANI**

Inquiry
nr: **52 424 377**

Pages: **04**

Sub: **technical offer nr. 2021-0015-B – KSC nozzle changer**

Dear Gentlemen,

we refer to your inquiry and tender nr.: 52 424 377 and offer you, with our offer nr. 2021-0015-B, according our general terms and conditions as following:



SHEFFIELD HI-TECH REFRACTORIES
Germany GmbH

		Number of strands		6				6		
		total tundish quantity - tundish in circulation		6	5			6		
		KSCO NC-18 offer	Quantity (pcs)			Amount in EURO FCA SHEFFIELD				
			General	Plant	Spare	Unit Price (€)	General	Plant	Spare	
Item No	Item number	Explanation	Grand total	Plant	Spare		Grand total(€)	Total(€)	Total(€)	
PLANT MECHANISM GROUP	1	NC-18	NC-18 MECHANISM (EXCLUDING HEAT SHIELD) (RIGHT LOADING)	42	30	12		0,00 €	0,00 €	0,00 €
	2	FS122.10.03SX	SPRING FOR CNC	208		208		0,00 €	0,00 €	0,00 €
	3	FS122.10.08-K	HEAT SHIELD	72	30	42		0,00 €	0,00 €	0,00 €
	4	FS122.10.07B	T-BOLT 150	316	60	256		0,00 €	0,00 €	0,00 €
	5	FS122.D.6331	FLANGED NUT	316	60	256		0,00 €	0,00 €	0,00 €
	6	FS122.D1587	BLIND NUT	316	60	256		0,00 €	0,00 €	0,00 €
	7	NC-R2	EXTENDED PLATE LOADER ASSY. (EXCLUDING WITH HYDRAULIC CYCLINDER) (RIGHT LOADING)	18	12	6		0,00 €	0,00 €	0,00 €
	8	NC-HC-1	NC-18 CYCLINDER	24	12	12		0,00 €	0,00 €	0,00 €
	9	FSCNCKECE	SEALING KIT FOR CYCLINDER	25		25		0,00 €	0,00 €	0,00 €
	10	FS122.10.04	RACKER	144		144		0,00 €	0,00 €	0,00 €
	11	FS122.10.05	RACKER SHAFT	72		72		0,00 €	0,00 €	0,00 €
	12	FS122.10.07	T-BOLT 75	144		144		0,00 €	0,00 €	0,00 €
PLANT NEED								0,00 €	0,00 €	0,00 €
INVESTMENT GROUP	1	FS200.00.00	TUNDISH ADAPTER PLATE (ASSY.) FOR 6 TUNDISHES WITH 6 STRANDS	42	36	6		0,00 €	0,00 €	0,00 €
	2	FS300.00.00	PREPARATION TABLE ASSY.	2	1	1		0,00 €	0,00 €	0,00 €
	3	FSNCYTA	CHECKING TOOL FOR SPRING	2	2			0,00 €	0,00 €	0,00 €
	4	FSNCTD	NC-18 SPRING TEST DEVICE	2	1	1		0,00 €	0,00 €	0,00 €
	5	FSNCOGT	OPEN GATE TOOL	2	1	1		0,00 €	0,00 €	0,00 €
	6	FSNCPCT	PLATE CENT. TOOL (WILL BE DEFINED AS NOZZLE DIAMETER)	4	4			0,00 €	0,00 €	0,00 €
	7	FSNCLC	MECHANISM LOADING CAR	1	1			0,00 €	0,00 €	0,00 €
	8	FSRMTMP	TEMPLATE FOR RAMMING	12	6	6		0,00 €	0,00 €	0,00 €
	9	FSPNHMFRRAM	PENUMATIC HAMMER FOR RAMMING	2	1	1		0,00 €	0,00 €	0,00 €
	10	FSNCKNTRUNT 6	ELECTRIC AND HYDRAULIC UNIT (6 STRANDS)	2	1	1		0,00 €	0,00 €	0,00 €
INVESTMENT TOTAL								0,00 €	0,00 €	0,00 €
GRAND TOTAL - PRICE IN EURO FCA Sheffield								0,00 €	0,00 €	0,00 €
NOTE 1:	THE ORDER WILL BE READY TO SHIP WITHIN 3-4 MONTH AFTER THE RECEIPT ORDER AND POWNPAYMENT.									
NOTE 2:	FS200.00.00 NUMBERED PART HAS TO BE ASSEMBLED WITH WELDING AND BOLT TO TUNDISHES THAT CAN BE USED.									
NOTE 3:	BUYER IS RESPONSIBLE TO PROVIDE, AIR TICKETS (DOMESTIC AND INTERNATIONAL), LIVING AND ACCOMODATION FOR THE SUPERVISORS . COMISSIONING IS MAX. FOR 12 DAYS AND INCLUDED IN THE PRICE. ANY DELAYS DUE TO THE REASONS BEYOND OUR RESPONSIBILITY FOR EXAMPLE CABLING, PIPING AND ADAPTOR PLATE WELDING PRIOR TO THE VISIT, WILL BE INVOICED TO BUYER AT A RATE OF 500 EURO/PER MANDAY.									
NOTE 4:	FROM MATERIAL AND INSTALLATION OF ALL PIPING FROM HYDRAULIC UNIT TO TUNDISH CAR, AND FROM CABLING FROM ELECTRIC CONTROL CABINETS TO CONTROL PANELS AT TUNDISH ARE AT BUYERS RESPONSIBILITY. ALL RELATED CONNECTION DRAWINGS WILL BE PROVIDED BY SHEFFIELD.									



SHEFFIELD HI-TECH REFRACTORIES
Germany GmbH

Below numbers of refractory material is estimated for 2 years production (1,5 tundish / day)

Pos.	Item number:	description:	Total nr. of pc.	Price per pc. FCA Sheffield	Total price FCA
1	CNF120-200U3	Upper, fix nozzle for NC system, 20 mm dia	10.500		
2	CNF120-170	Lower, changeable nozzle for NC system, 17 mm dia	2.900		
3	CNF120-175	Lower, changeable nozzle for NC system, 17,5 mm dia	7.500		
4	CNF120-180	Lower, changeable nozzle for NC system, 18 mm dia	5.600		
5	CNF120-185	Lower, changeable nozzle for NC system, 18,5 mm dia	9.700		
6	CNF120-190	Lower, changeable nozzle for NC system, 19 mm dia	5.500		
7	BP120-50	Blank plate for NC system	3.000		
8	FG17080	Gasket for upper nozzle	11.000		



SHEFFIELD HI-TECH REFRACTORIES
Germany GmbH

Pos.	Item number:	description:	Total nr. of pc.	Price per pc. FCA Sheffield	Total price FCA
9	SHR M 92	Ramming material	150 ton		

General conditions:	
Payment terms:	50 % down payment, 50 % before shipment
Delivery time:	ca. 4 month for first order, ca. 1-2 month for regular shipments
Offer valid until:	31.12.2021

We hope that this offer is according your expectations and would be happy to start our cooperation with an order from you.

With Best Regards
Sheffield Hi-Tech Refractories Germany

Jörg Breitfuss
Sales manager



This document is strictly CONFIDENTIAL and PROPERTY of Sheffield Hi-Tech Refractories
Any copying or disclosure of this document is strictly forbidden

 SHEFFIELD HI-TECH REFRACTORIES Germany GmbH	Technical Information Sheet	Refractory Division
	Material: SHR M 92	Product Information

Specifications:

Type of product:	Ramming mix
Class:	PRE Class D
Pyrometric cone:	>2000°C
Main component:	Magnesia
Maximum grain size:	0-8 mm
Bond system:	Chemical
Packing:	25 kg paper bags
Install method:	By ramming
Recommended service limit:	1750°C
Specific gravity:	2,75
% Water addition:	4,5 – 5,0
Storage conservation:	6 months (room temp.)

Chemical Analysis [%]	Typical [%]
MgO	93
CaO	1,1
P ₂ O ₅	1,35
SiO ₂	2,6

Document History :

Issue Date	Issue Number	Approval	Detail of Change
23/07/2013	2	TBR	New layout

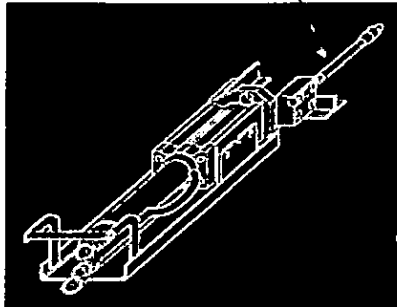
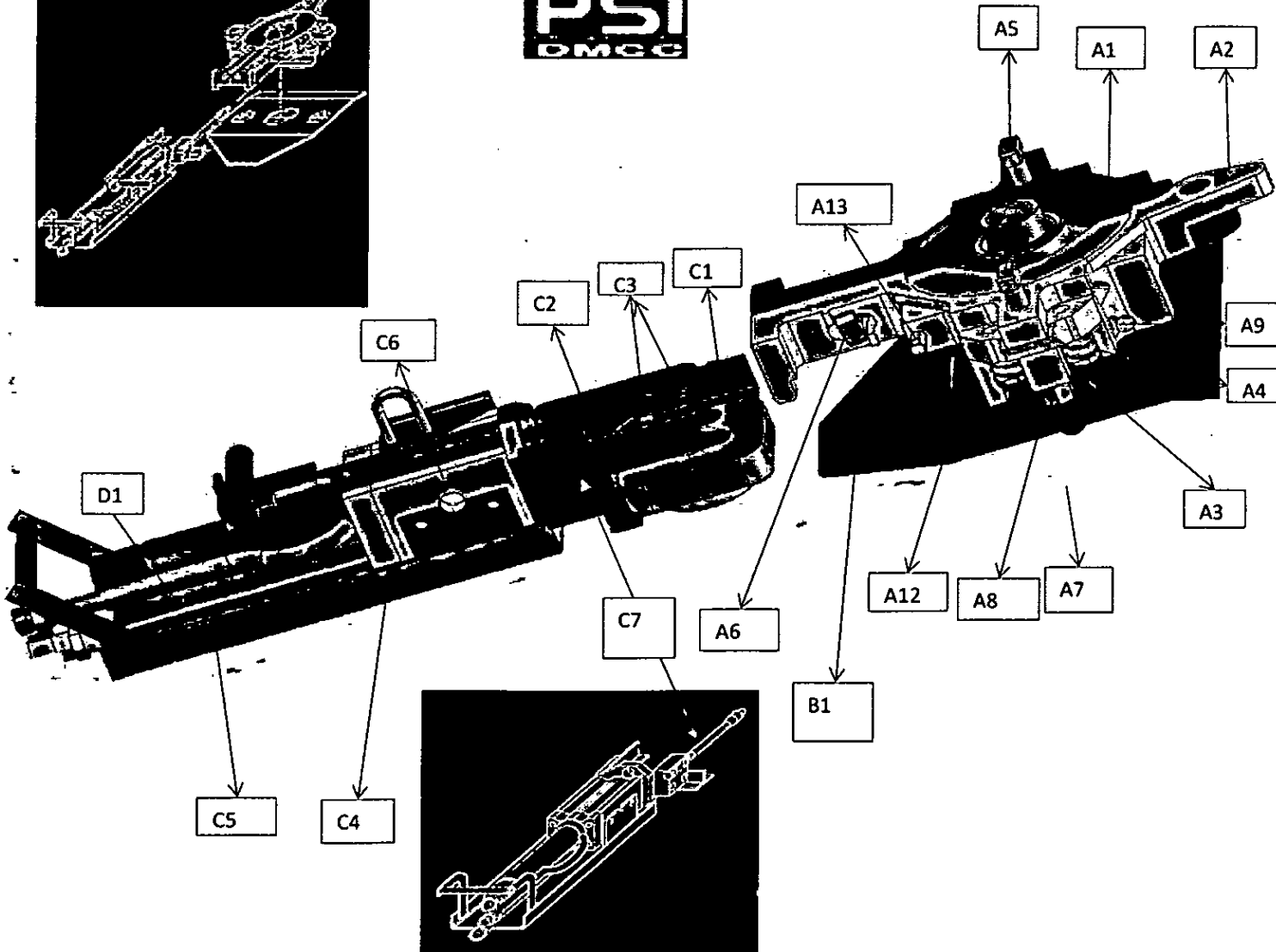
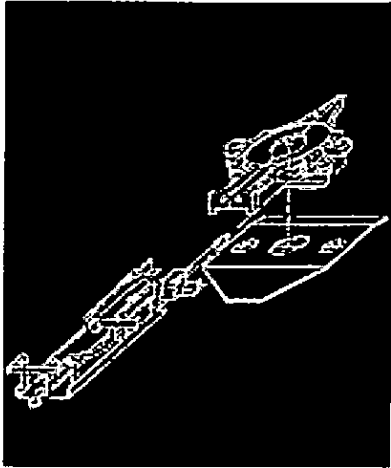

CNC MECHANISM			
GROUP	FS	EXPLANATION	QUANTITY

Group A	A1	Male part	1
	A2	Female part	1
	A3	Racker	4
	A4	Spring	4
	A5	T-Bold 150	2
	A6	T-Bold 75	1
	A7	Nut DIN 6331 M16	2
	A8	Nut DIN 1587 m16	1
	A9	Rocker Şaft	2
	A10	Pin	2

Group B	B1	CNC Heat Shield	1
---------	----	-----------------	---

Group C	C1	Nozul holder (complete)	1
	C2	Nozul pusher	1
	C3	Magnet	2
	C4	Cylinder support	1
	C5	Loader heat shield and air cooling system	1
	C6	hanging part	1
	C7	Loader centering and locking pin	1

Group D	D1	CNC Cylinder	1
---------	----	--------------	---

NOTE: numbered C7 part was changed as pin at below.

SHR

Do Not Draw Below of patent License on
 Sheffield H. Tech. Refractories Service, Ltd.
 The copyright in this drawing is the property of
 Sheffield H. Tech. Refractories Service, Ltd.
 The unauthorized use of this document or use contrary to its
 intended purpose is not permitted and shall be prosecuted.

The content of this sheet is copyright property of
 Sheffield H. Tech. Refractories Service, Ltd.
 The unauthorized use of this document or use contrary to its
 intended purpose is not permitted and shall be prosecuted.

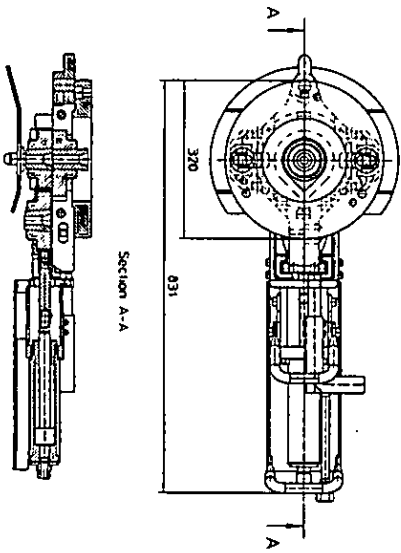

Section A-A

Nozzle Changer
 scale 1:5

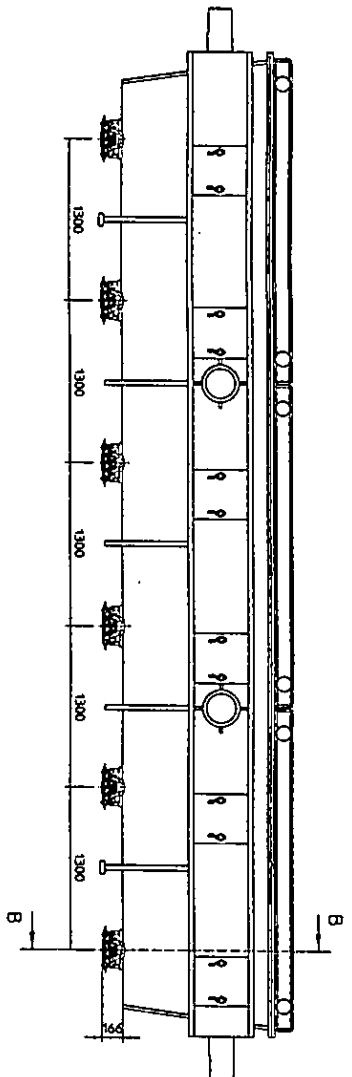
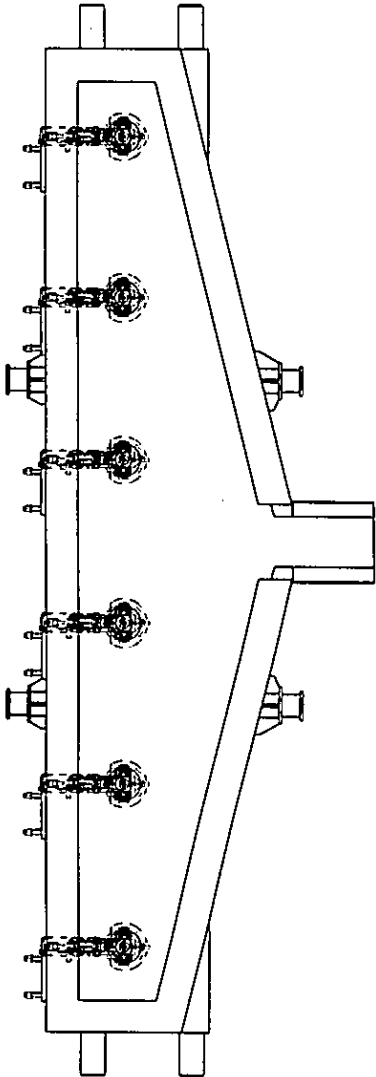
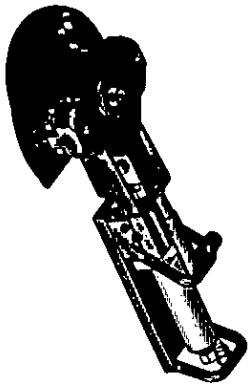

Section B-B

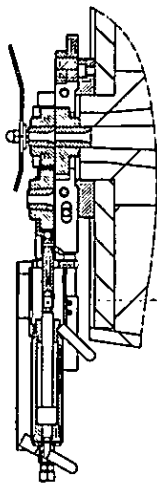

DETAIL 1
 scale 1:5

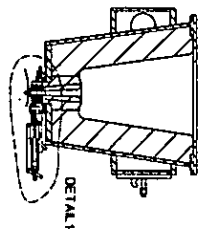

DETAIL 1



Part No.	000-0000-00-0000
Part Name	Nozzle Changer NC-18
Material	BRZ/ST/61
Quantity	61
Manufacturer	STR
Scale	1:5
Sheet No.	A1

Nozzle Changer NC-18
 000-0000-00-0000

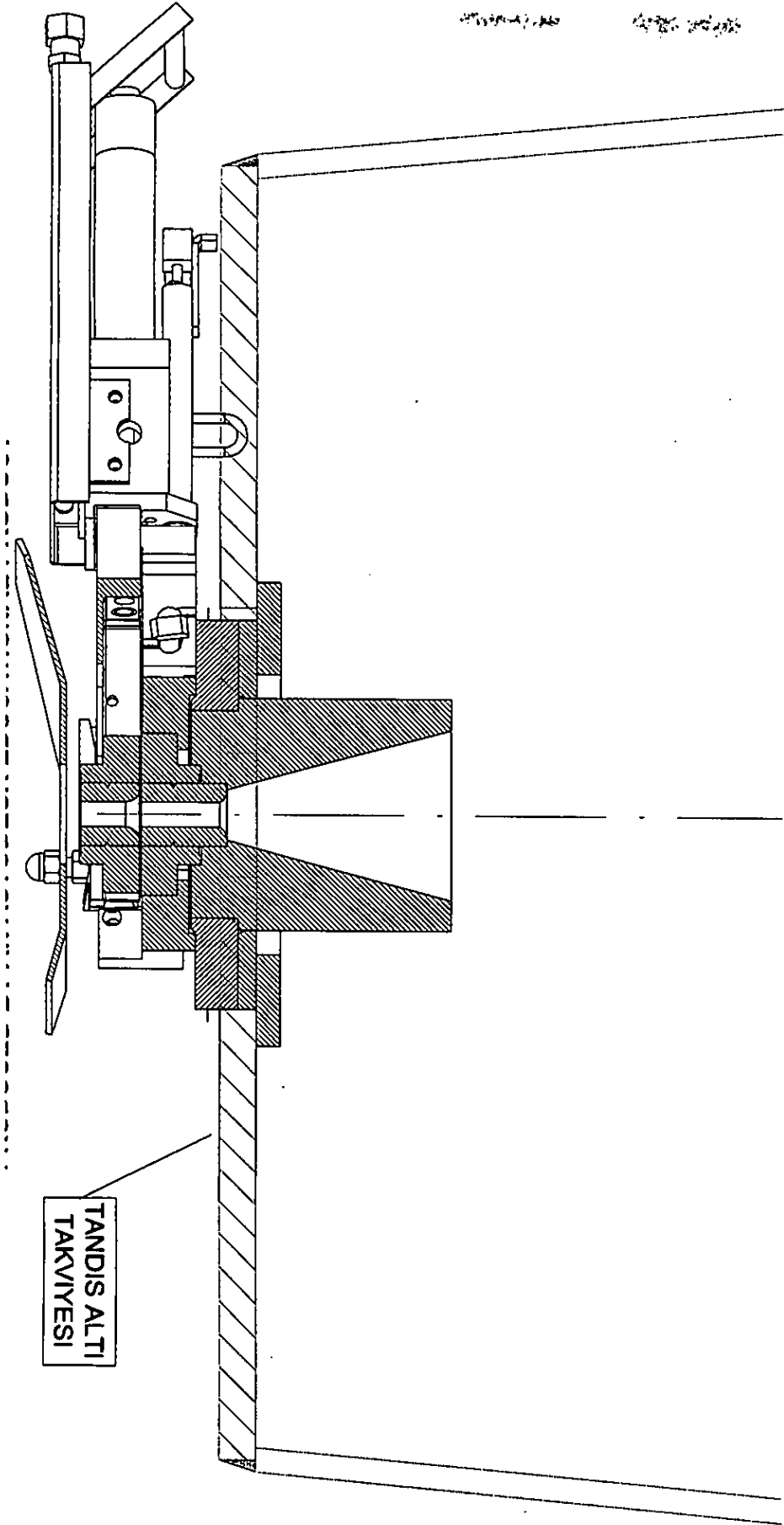

TANDIS ALTI
TAKVIYESI

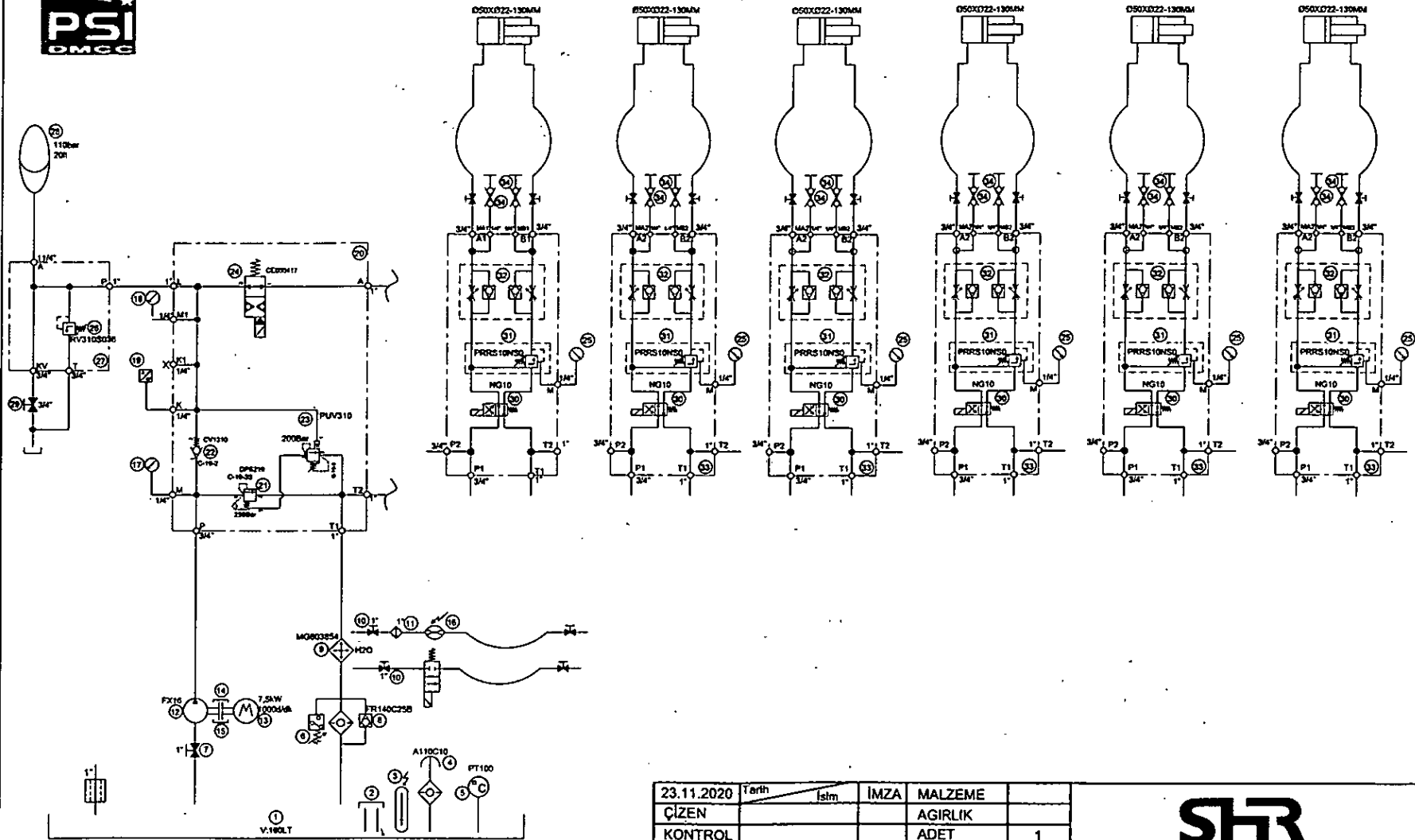

23.11.2020	Tarih	İsm	İMZA	MALZEME
ÇİZEN				AGIRLIK
KONTROL				ADET 1
ONAY				ÖLÇEK

STR



HYDRAULIC UNIT FOR TUNDISH
NOZZLE CHANGER SYSTEM (6
STRANDS)

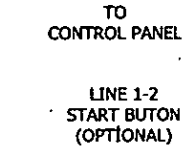
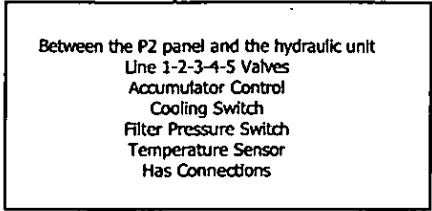
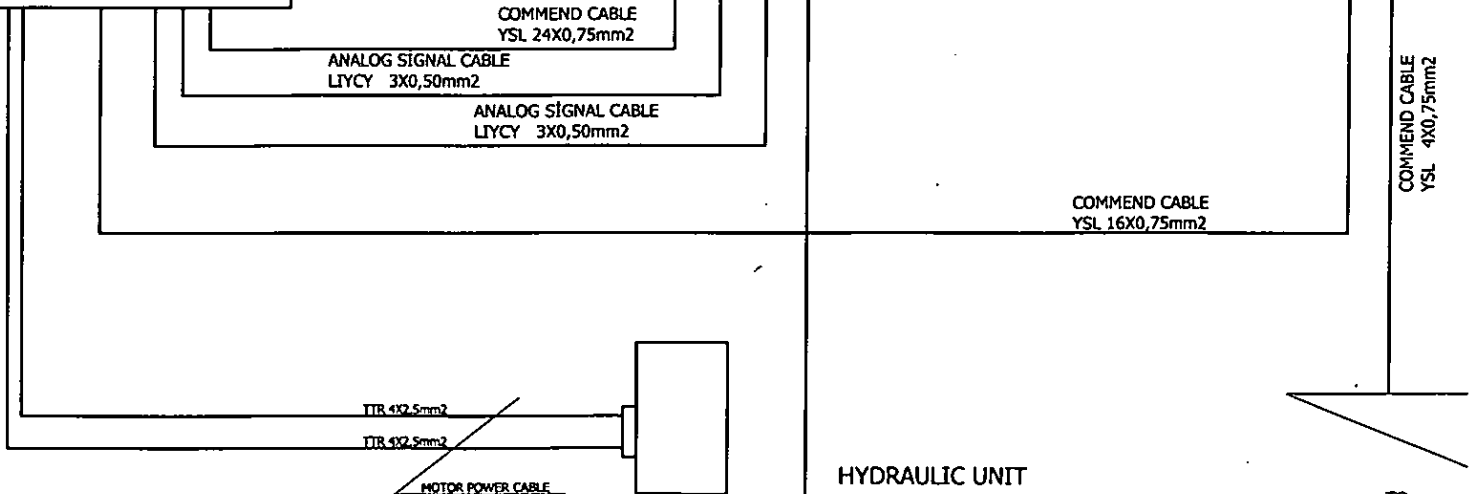
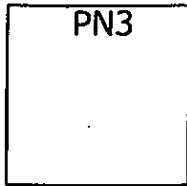
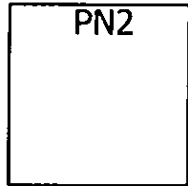
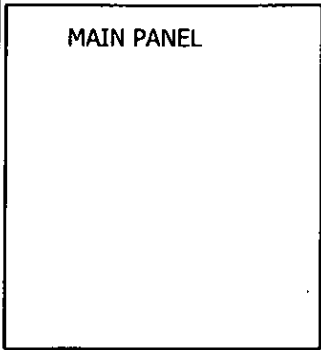

15

Datum					CABLE				
Bearb. Live					SHR				
Plot 22.11.2020									
Änderung Datum Name Form. DPAH 4.10.14.09.03					Urspr. Ers.f. Ers.d.				
Bl. 16									